

**! WARNING! - ACHTUNG! - UWAGA! - AVERTISSEMENT!**

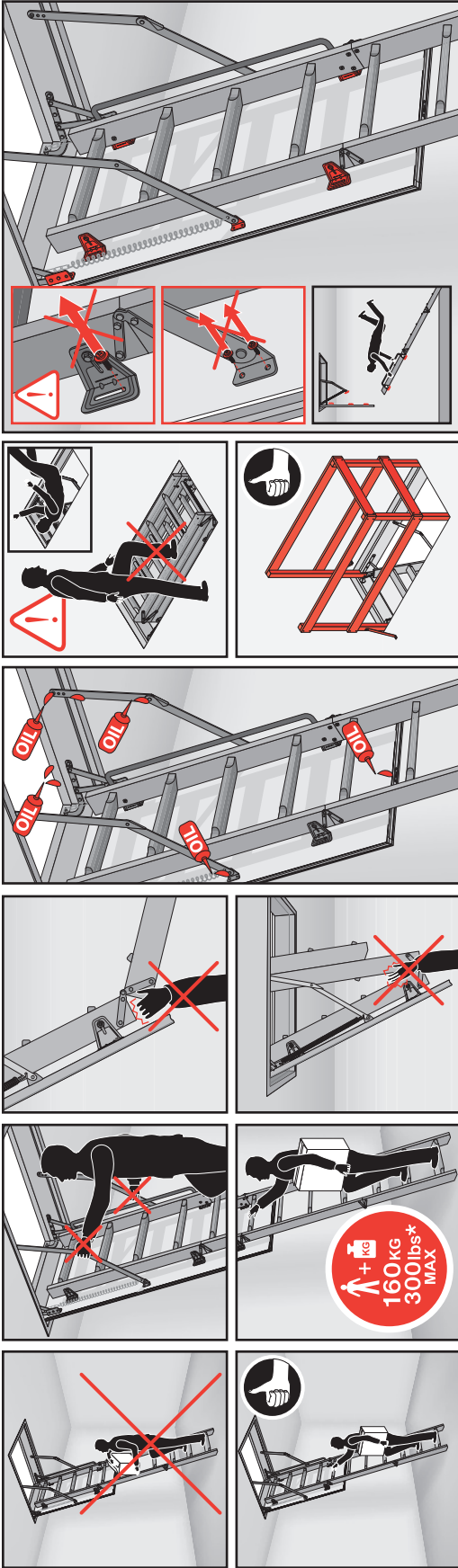

www.fakro.com

EN 14975 : 2006

\*ANSI 14.9 - 2004

**FAKRO®**

# Мир Кровли

+7 (495) 981 19 21

www.krovlja.ru

LWS LWS-P



LWK LWK-P LTK



NC 99A

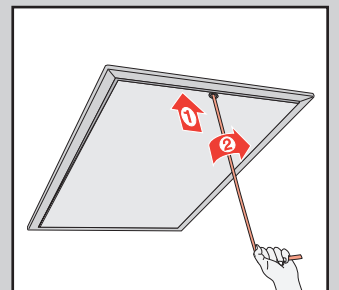
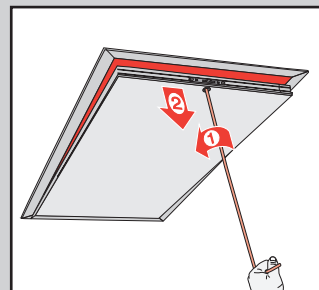

1

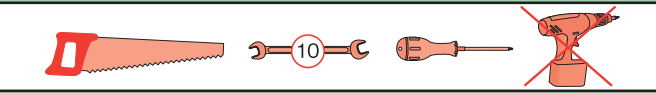
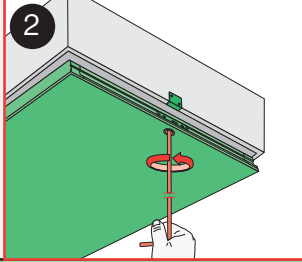
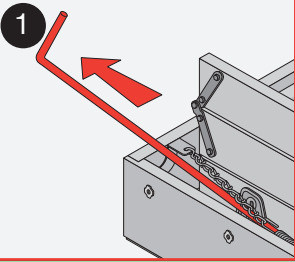
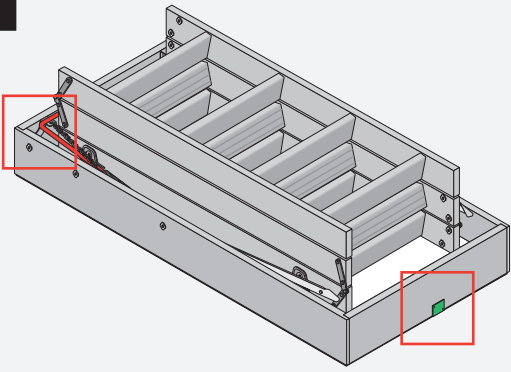

2

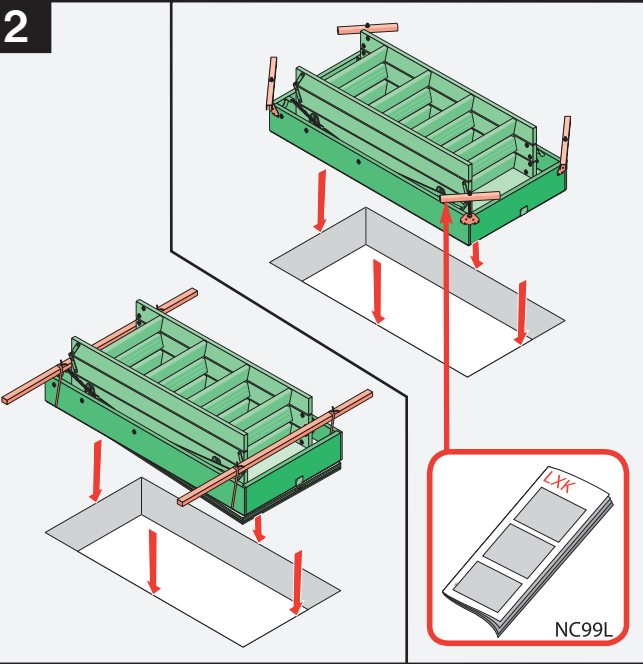

3

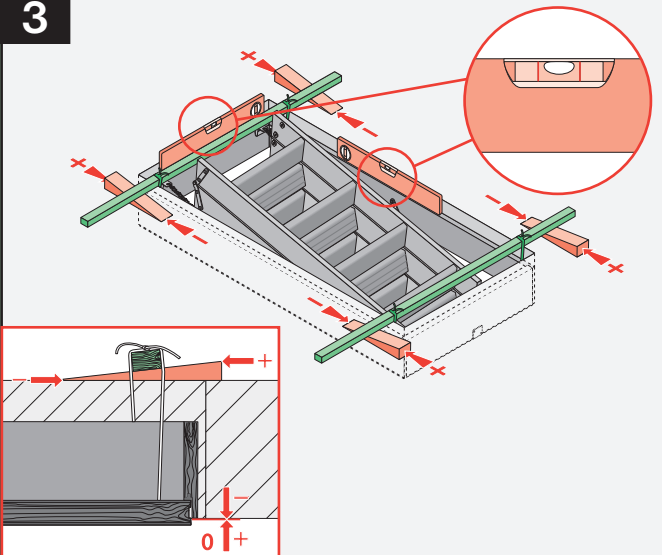

4

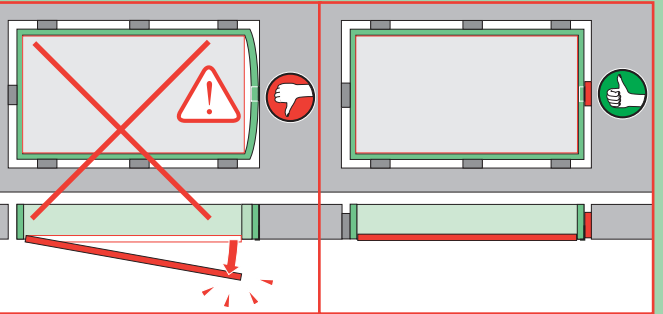
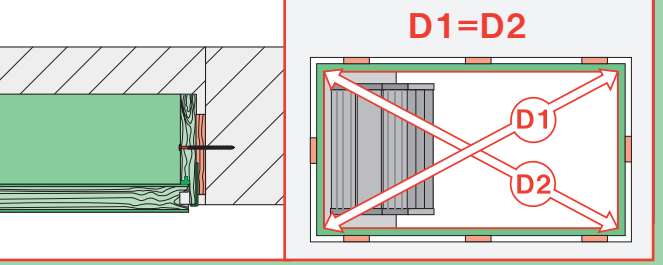
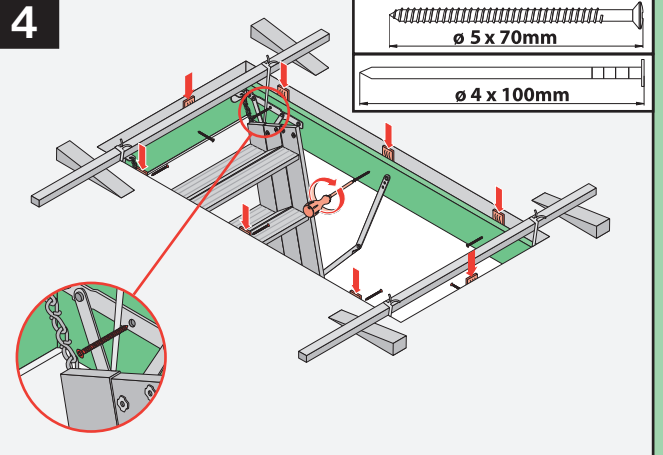

5

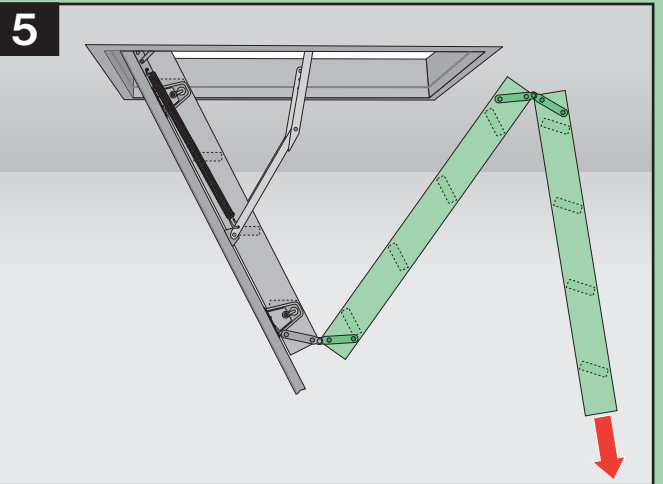

6

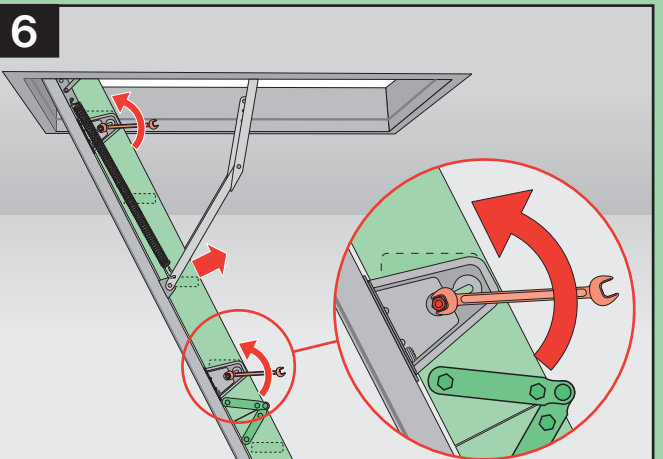

7

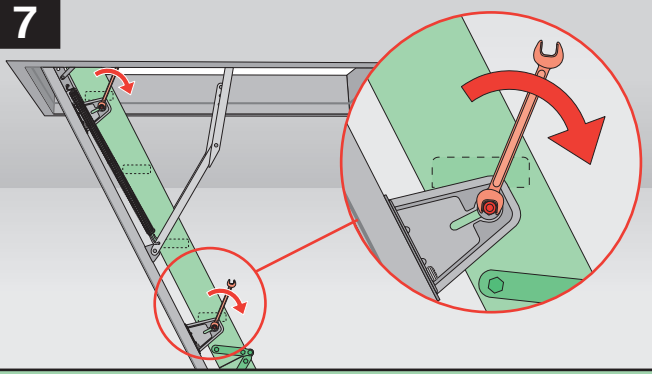

8

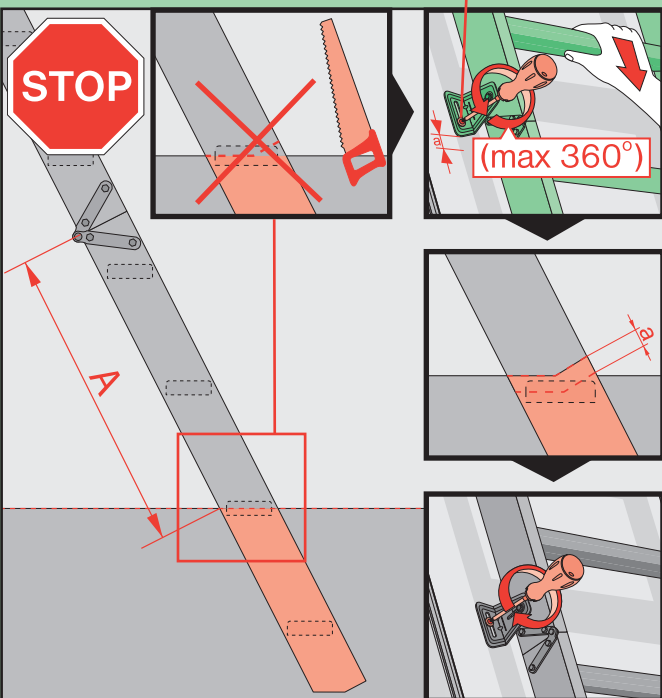
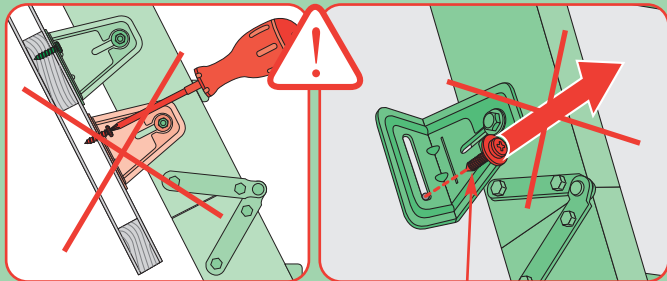
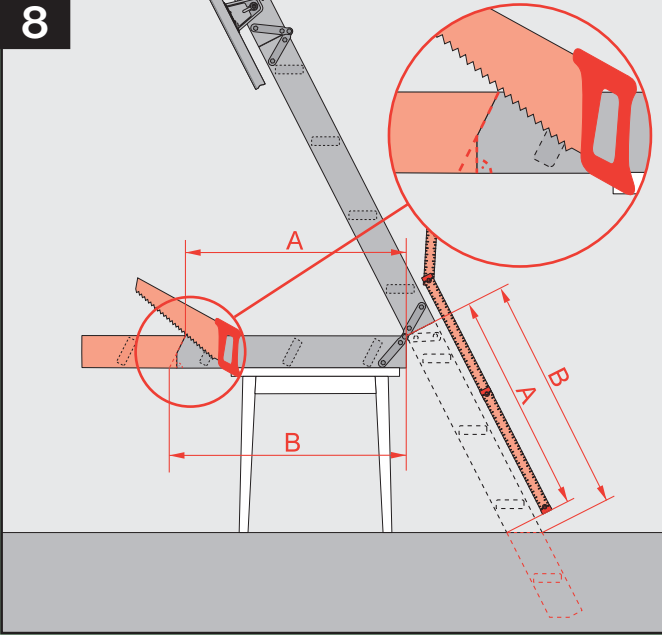

9

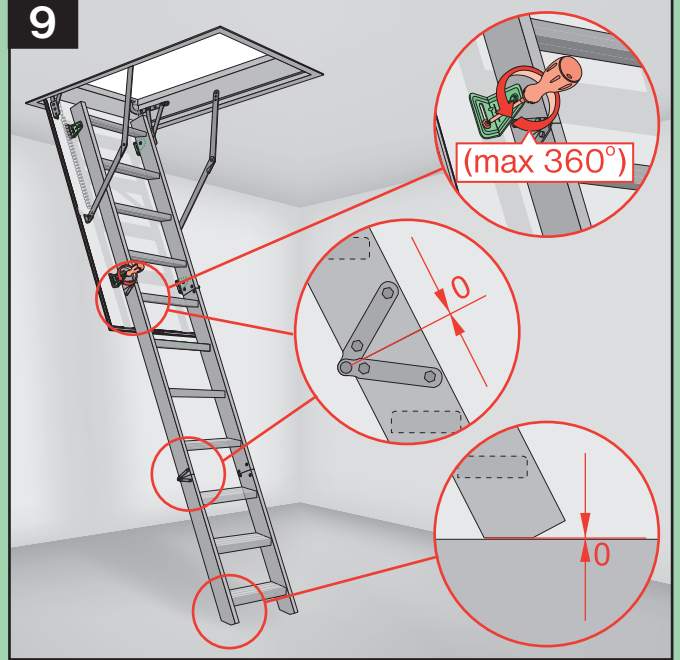

10

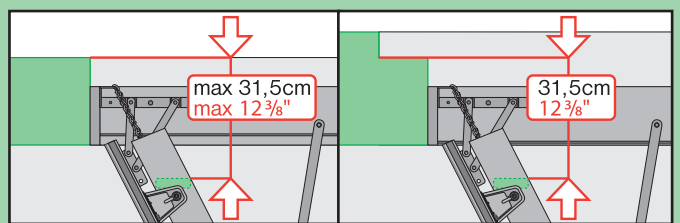
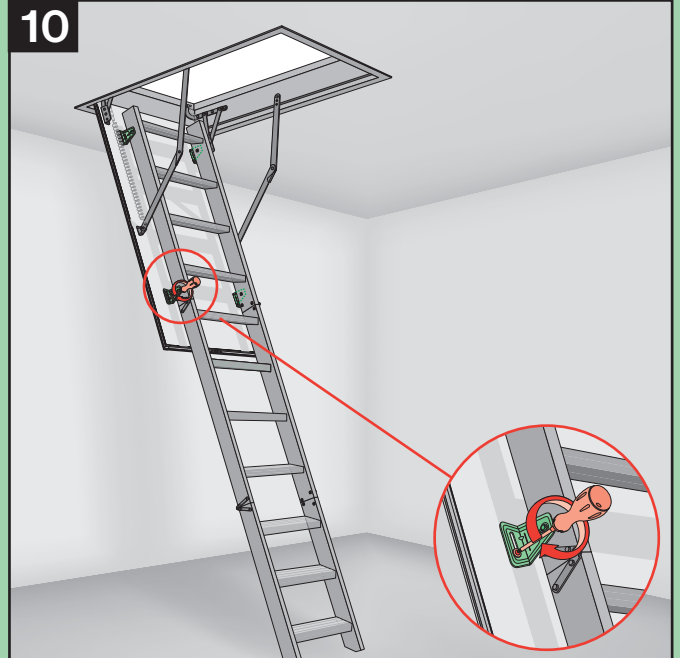

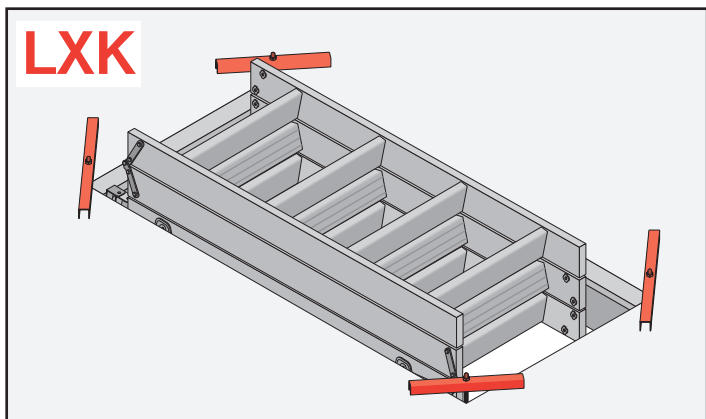
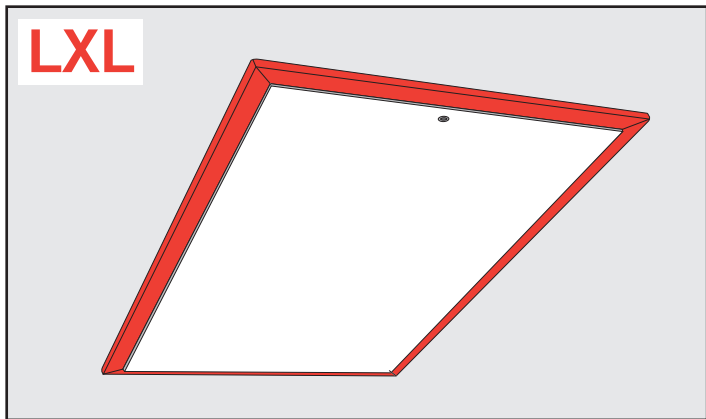
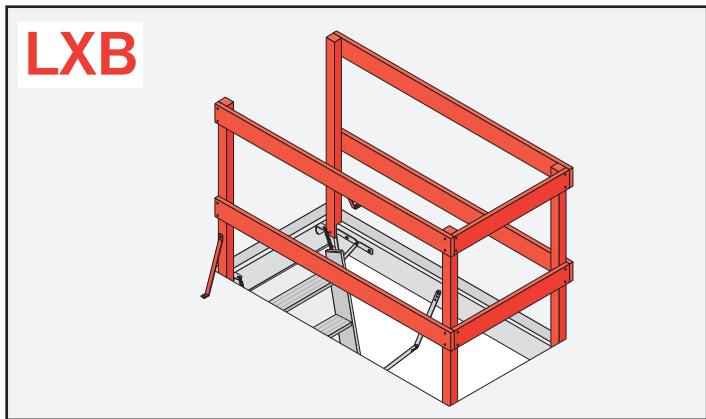
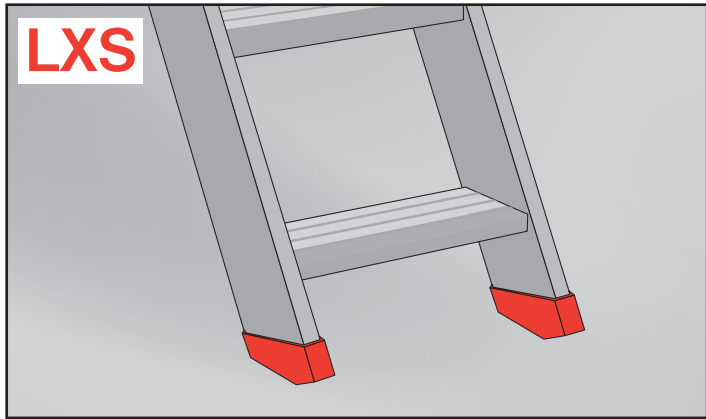
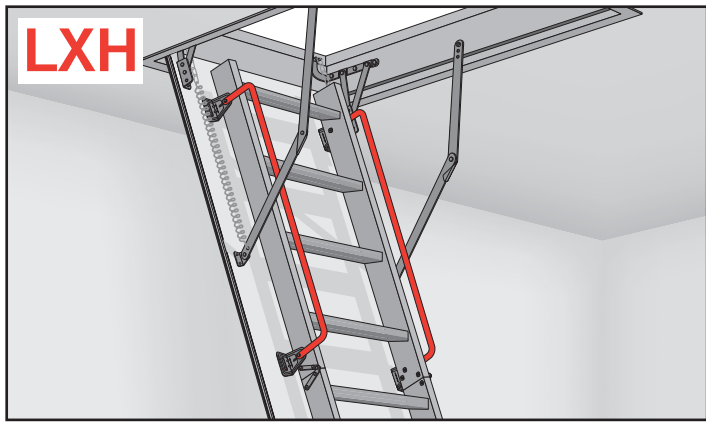

LWK

LWK-P

LTK

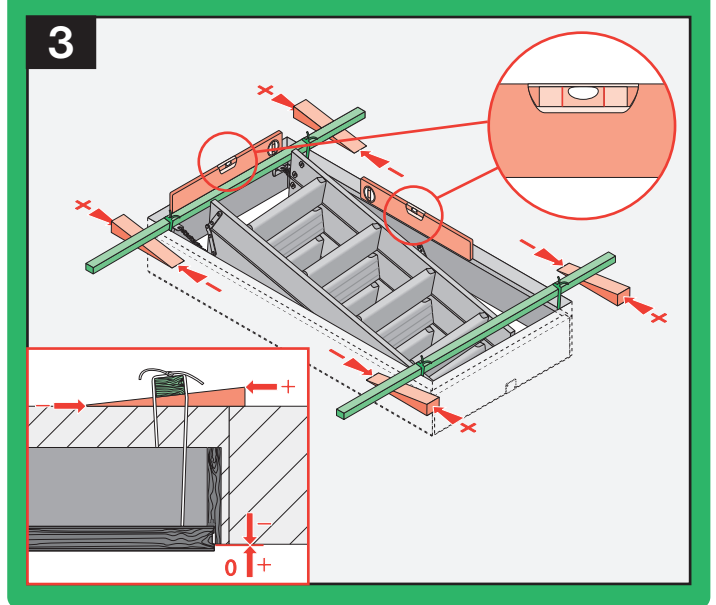
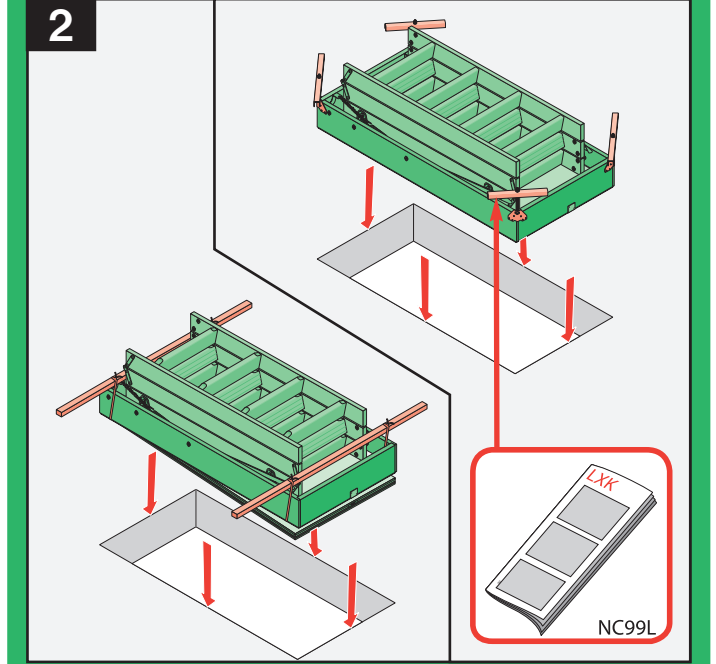
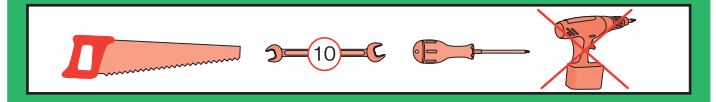
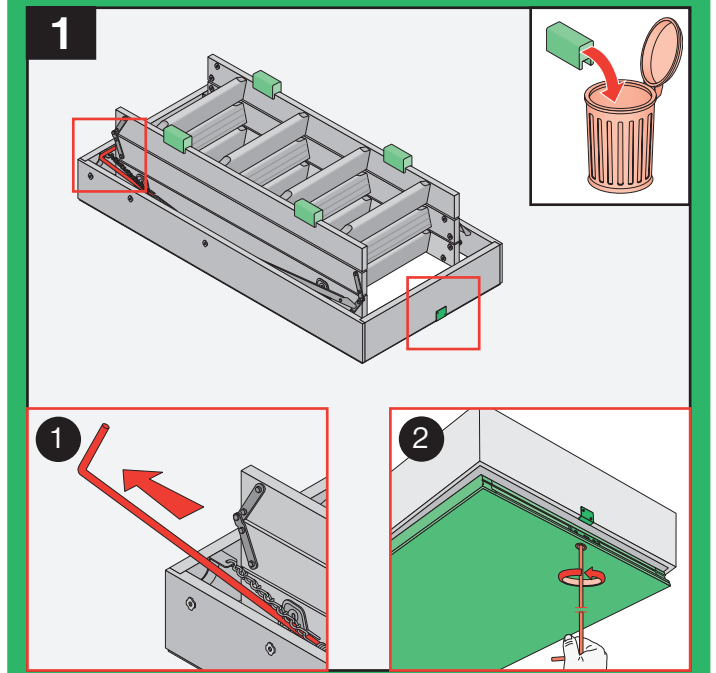



4

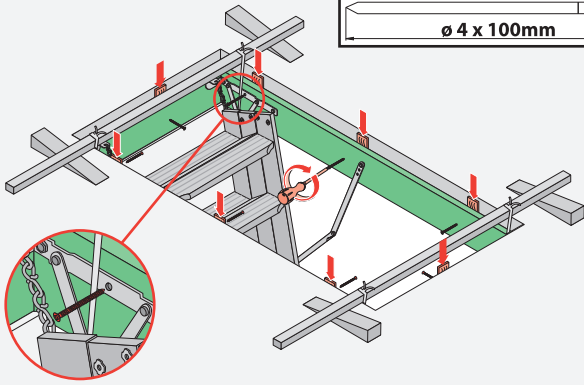
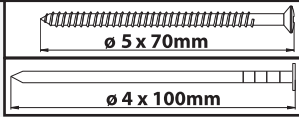

D1=D2

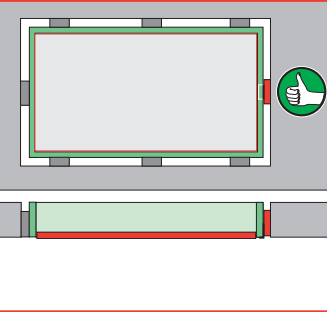
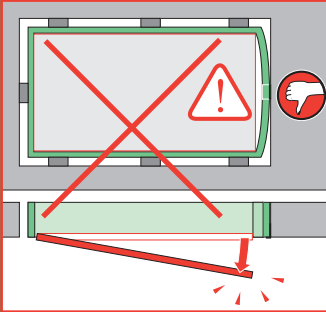
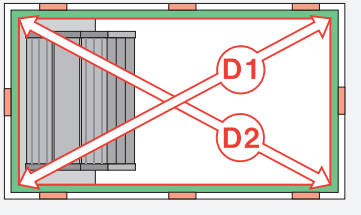
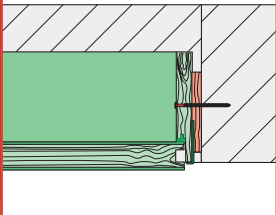

5

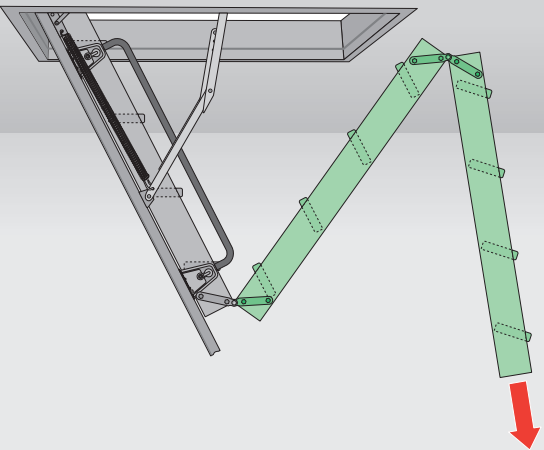

6

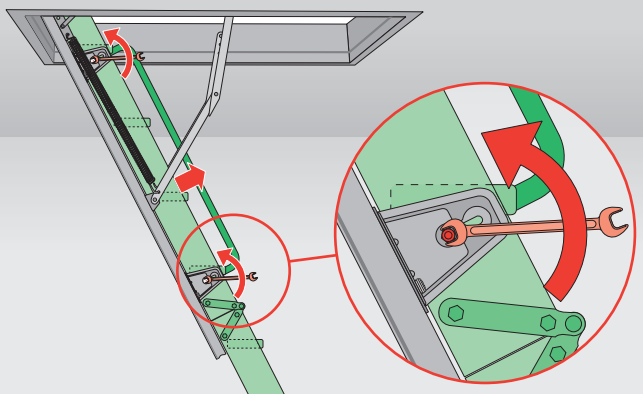

7

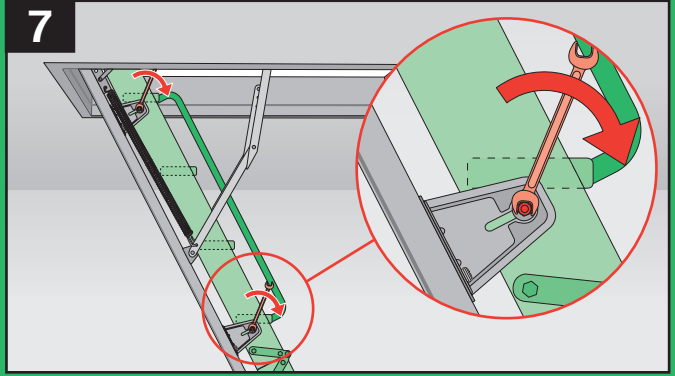

8

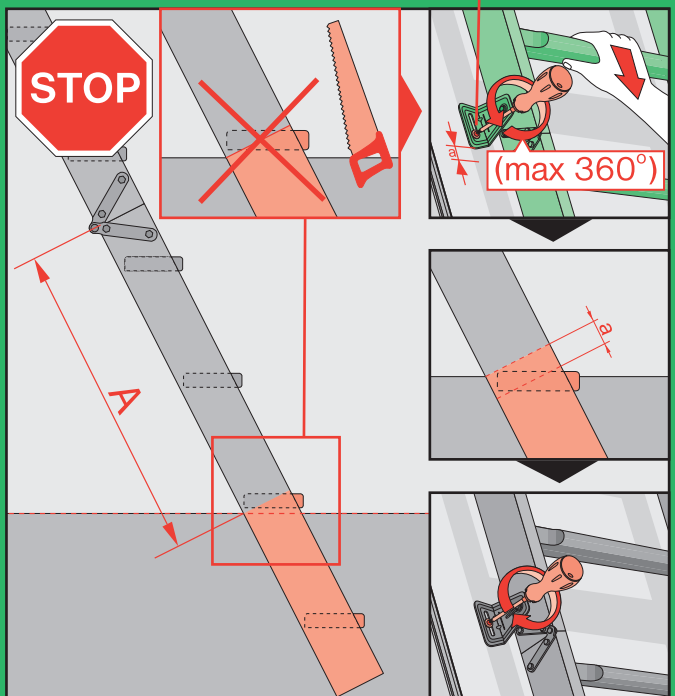
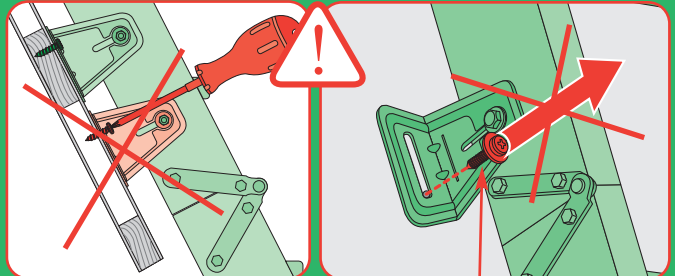
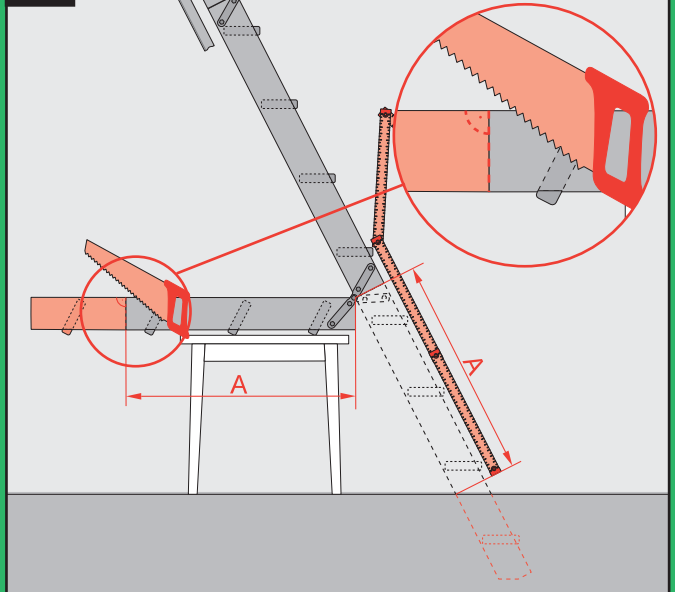

LWK

LWK-P

LTK

9

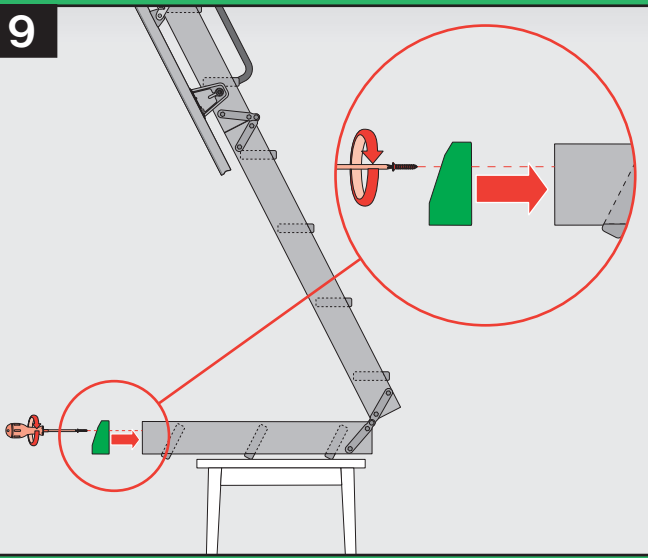

10

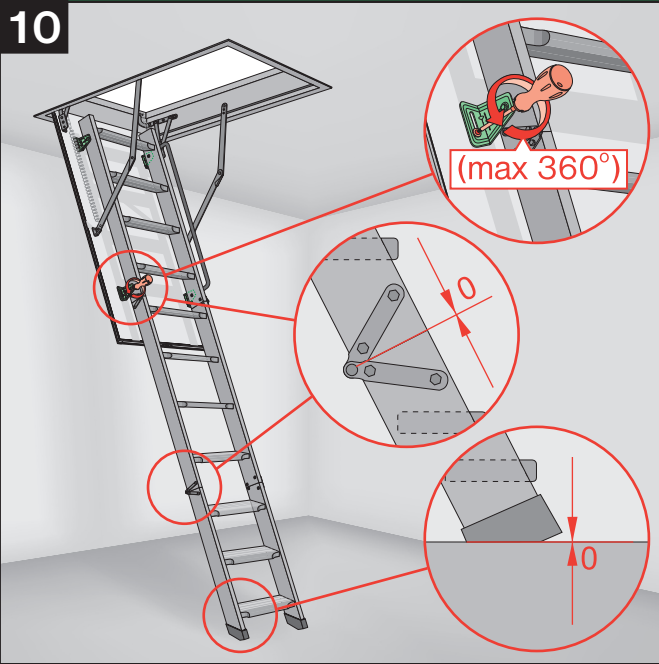

11

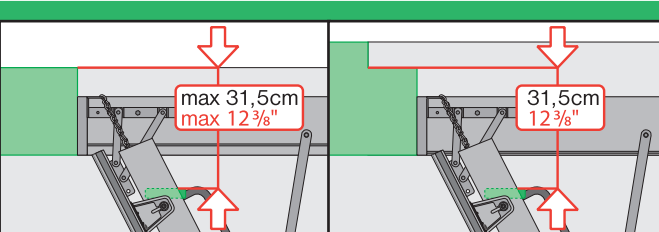
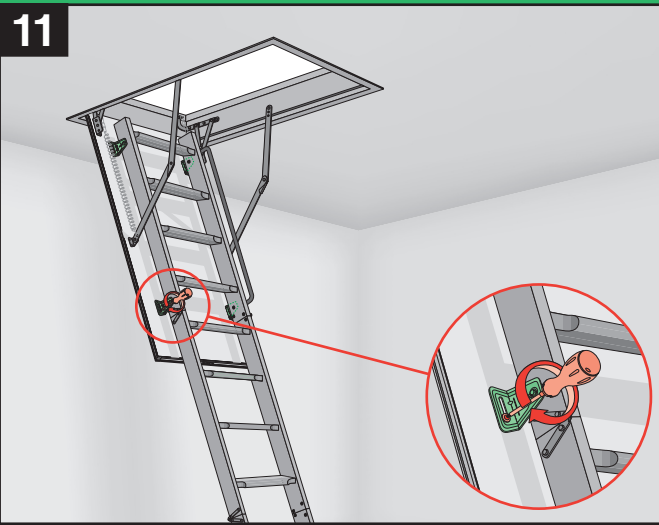

10

LXH

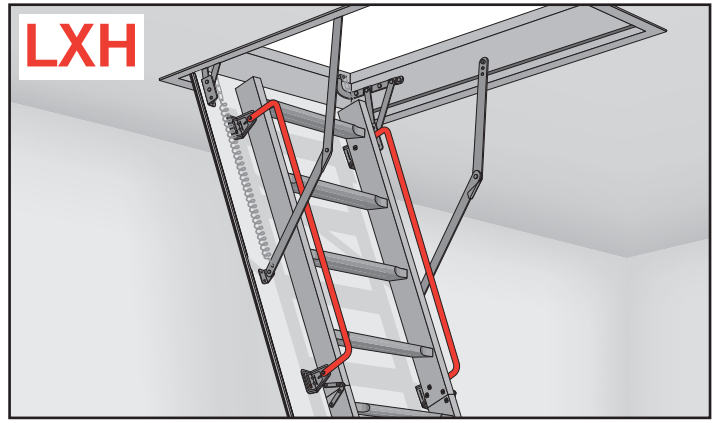

LXS

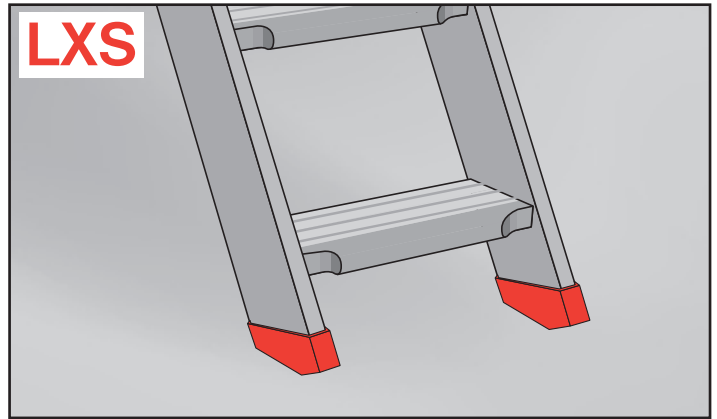

LXB

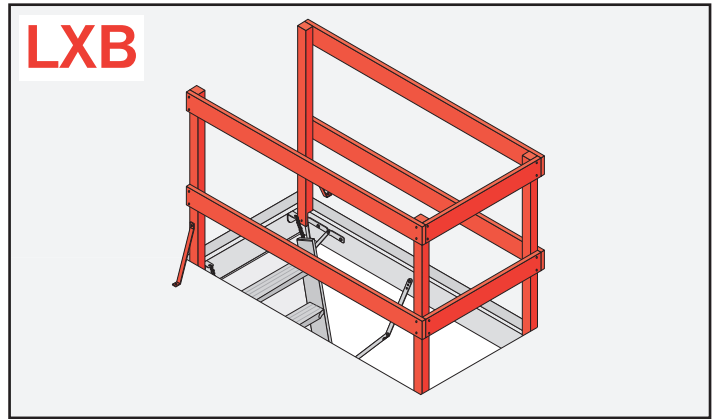

LXL

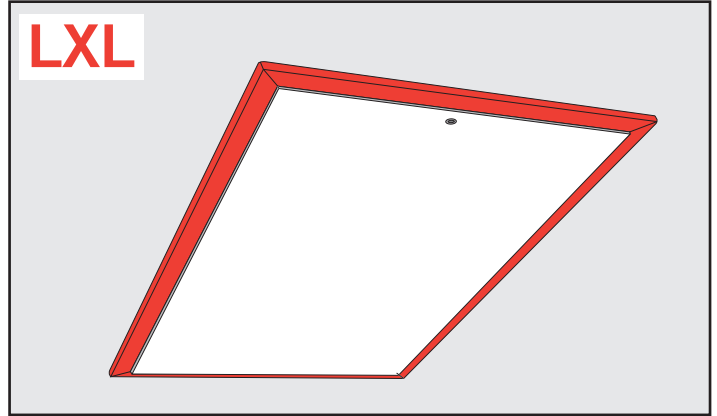

LXK

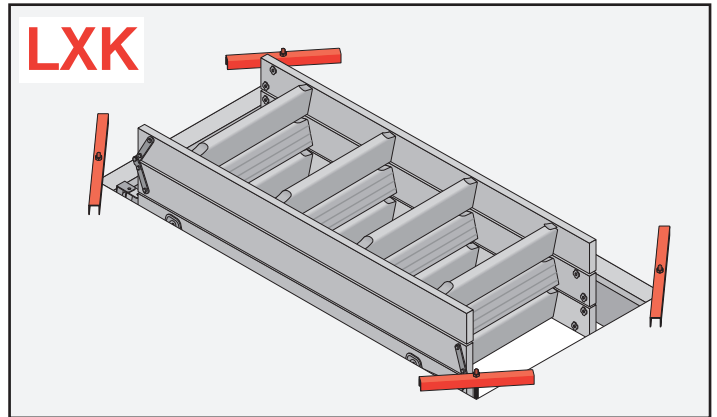

11